

#	DESCRIPTION	DATE	APPROVED

PRE-INSTALLED: QTY. 3 14237 SCREW. ALUMINUM WITH HEX SOCKET DRIVE

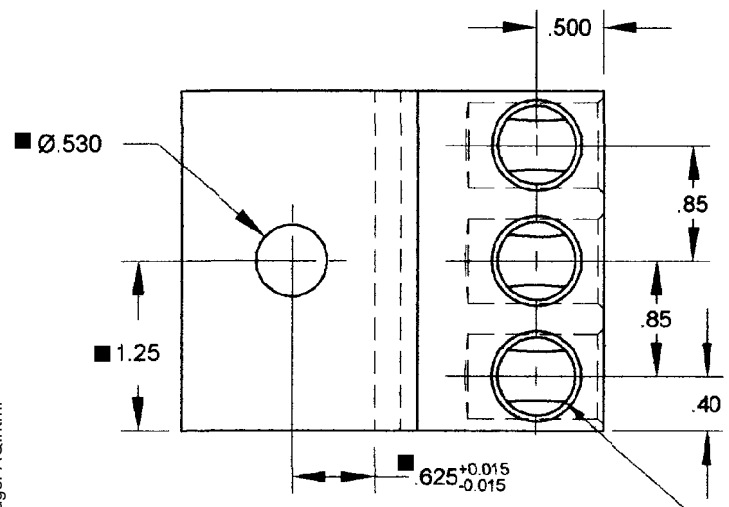

IHI UL/CSA Installation Guide to Drill or Enlarge Mounting Holes:
<https://lugsdirect.com/PDF Documents/IHI-MTG-HOLE-FIELD-MODS-UL&CSA-CERTIFICATIONS.pdf>

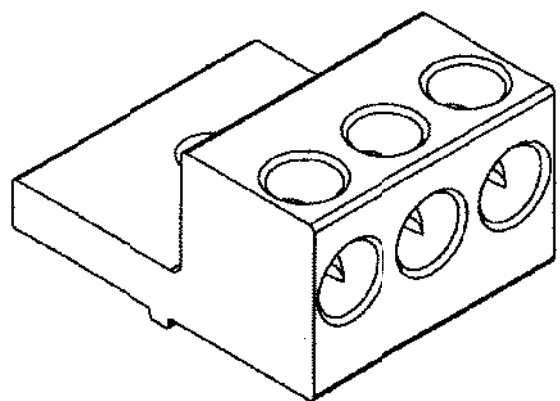

TAP 5/8-18UNF-2B
(3 PLACES)

Cat. No. 2S250 Style No. 2

- Drill, Enlarge, or Modify Mounting Holes
- 1) Increase hole(s) dia. to 11/16 bolt.
- 2) Move location of mounting hole(s)
- 3) If buying blank lug, put custom hole(s) in.

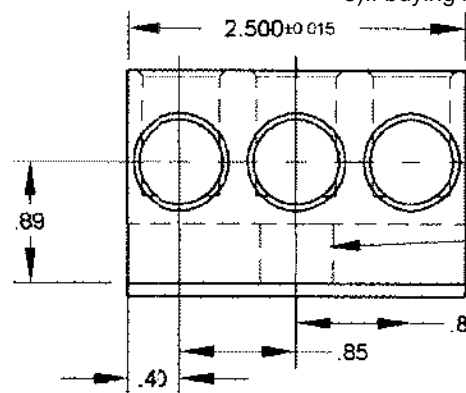
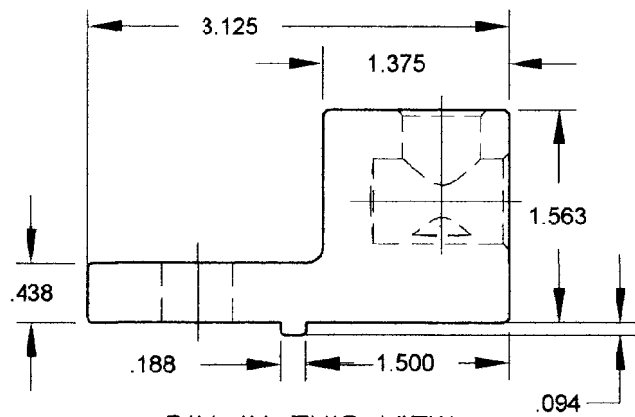

MARKING TO INCLUDE THE FOLLOWING:
 IHI 2S250
 250 KCMIL-6
 UL CSA CU9AL

DIM IN THIS VIEW FOR REF. ONLY

THIS DRAWING AND DESIGN ARE THE PROPERTY OF INTERNATIONAL HYDRAULICS INC., CLEVELAND, OHIO, AND MAY NOT BE DUPLICATED, USED FOR BASIS OF DESIGN, OR MANUFACTURE WITHOUT THE WRITTEN PERMISSION OF INTERNATIONAL HYDRAULICS INC., CLEVELAND, OHIO.

GENERAL TOLERANCES ±.015 (±0.038)

INTERNATIONAL HYDRAULICS, INC.

TITLE:
3S250TP MFG. DRAWING

SIZE: A	DRAWN BY: TDS	CHECKED BY: XX	DRAWING: 14398	REV: 0
DATE: 12/19/02		SCALE: .75	THIS IS A CAD DRAWING. DO NOT MANUALLY REVISE	

FLEX WIRE 3/0-6 AWG

NOT FOR USE WHERE FAILURE CREATES A HAZARD TO HUMAN HEALTH OR SAFETY. ALL PRODUCTS ARE SUBJECT TO THIS FULL DISCLAIMER: <http://www.ihiconnectors.com/disclaimer.html>
 FOR FURTHER INFORMATION ON THE PROPER USE OF THIS PRODUCT IN SPECIFIC APPLICATIONS SEE <http://www.ihiconnectors.com/GuideToFlexibleFineStrandedWireCableMechanicalLugsFAQ.html>
<http://www.ihiconnectors.com/Technical-Data-Installation.htm>